

GOL-007 Modelo **sem** Intermediário - Motor IP - 21

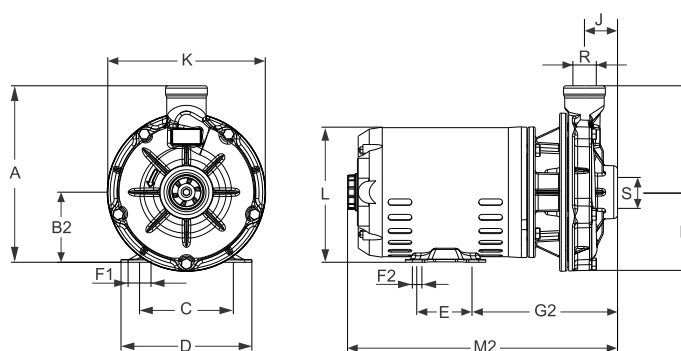

GOL-007X Modelo **com** Intermediário - Motor IP - 21

Potência	3/4 cv		1 cv		1,5 cv		2 cv		3 cv	
Cota (mm)	Mono	Trif	Mono	Trif	Mono	Trif	Mono	Trif	Mono	Trif
A	235	235	235	235	235	235	235	235	235	235
B1	101	101	101	101	101	101	101	101	101	101
B2	89	89	89	89	89	89	89	89	89	89
C	124	124	124	124	124	124	124	124	124	124
D	166	166	166	166	166	166	166	166	166	166
E	76	76	76	76	76	76	76	76	76	76
F1	31	31	31	31	31	31	31	31	31	31
F2	9	9	9	9	9	9	9	9	9	9
G1	123	123	123	123	123	123	123	123	123	123
G2	175	175	175	175	175	175	175	175	175	175
H	100	100	100	100	100	100	100	100	100	100
I	135	135	135	135	135	135	135	135	135	135
J	42	42	42	42	42	42	42	42	42	42
K	200	200	200	200	200	200	200	200	200	200
L	221	184	221	184	221	184	221	184	218	184
M1	292	285	312	295	332	315	342	342	365	355
M2	353	343	353	363	373	383	393	393	423	413
R (Rosca BSP)	1"	1"	1"	1"	1"	1"	1"	1"	1"	1"
S (Rosca BSP)	1 1/2"	1 1/2"	1 1/2"	1 1/2"	1 1/2"	1 1/2"	1 1/2"	1 1/2"	1 1/2"	1 1/2"
Peso sem Intermediário (kg)	11,9	14,9	13,4	16,9	18,9	18,9	19,9	20,9	24,9	22,9
Peso com Intermediário (kg)	15,2	18,2	16,7	20,2	22,2	22,2	23,2	24,2	28,2	26,2